

## ■ Dimensions Drawing

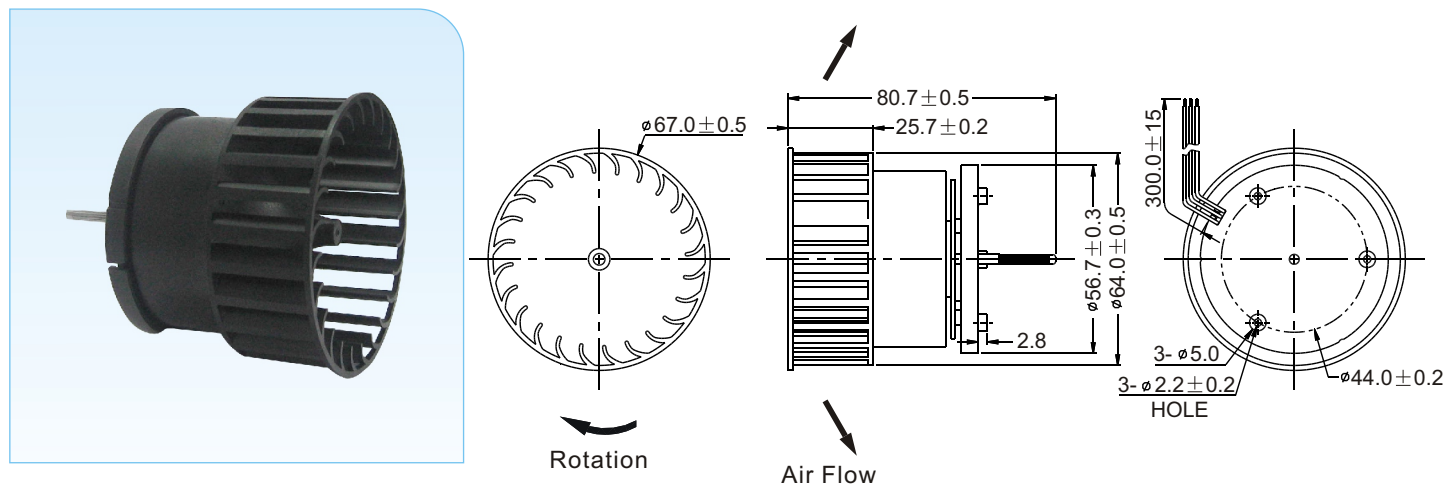

Unit: mm

## General Specification:

- Frame and Impeller : Thermal Plastic , UL 94V-0
- Lead Wires : UL Type  
(+) : Red (-) : Black
- Operation Temperature : -10°C~70°C、  
35%~85%RH
- Storage Temperature : -40°C~80°C、  
35%~85%RH



Listed Model	Bearing System	Rated Voltage	Operation Voltage	Rated Current	Rated Speed	Air Flow	Air Pressure	Noise Level	Available Features (Optional)				Weight
		VDC	VDC	A	RPM	CFM	mmH <sub>2</sub> O	dBA	Tachometer Output	Rotation Detector	Thermal Control	Pulse Width Modulation	g
RSH1262S	Sleeve	12	6.0~13.8	0.50	3,600	---	---	43	•	•			185
RSM1262S			6.0~13.8	0.30	3,000	---	---	39	•	•			
RSL1262S			6.0~13.8	0.25	2,500	---	---	34	•	•			