

97x94x33mm

■ Dimensions Drawing

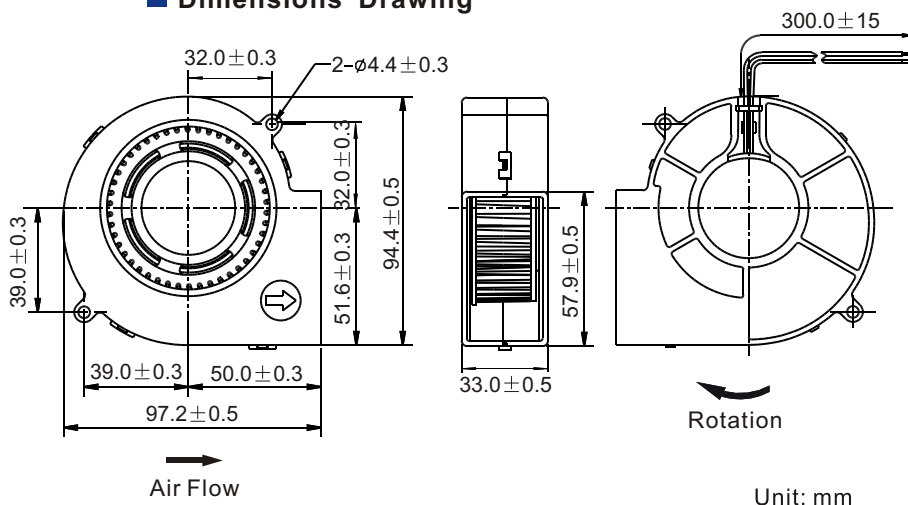

■ Performance Curves

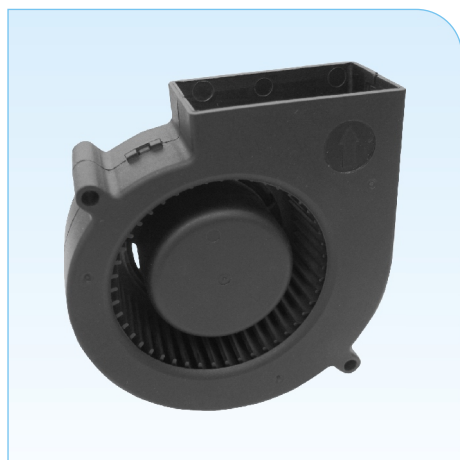
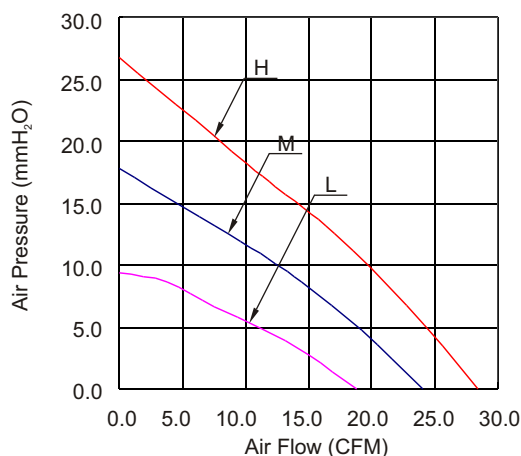

General Specification:

- Frame and Impeller : Thermal Plastic , UL 94V-0
- Lead Wires : UL Type  
(+) : Red (-) : Black
- Operation Temperature : -10°C ~ 70°C、  
35% ~ 85%RH
- Storage Temperature : -40°C ~ 80°C、  
35% ~ 85%RH



Listed Model	Bearing System	Rated Voltage	Operation Voltage	Rated Current	Rated Speed	Air Flow	Air Pressure	Noise Level	Available Features (Optional)				Weight
		VDC	VDC	A	RPM	CFM	mmH <sub>2</sub> O	dBA	Tachometer Output	Rotation Detector	Thermal Control	Pulse Width Modulation	g
RBH9733S	Sleeve	12	6.0~13.8	0.80	3,300	28.5	26.8	55	•	•	•	•	180
RBM9733S			6.0~13.8	0.50	2,800	24.0	17.8	51	•	•	•	•	
RBL9733S			6.0~13.8	0.30	2,200	18.8	9.4	45	•	•	•	•	
RBH9733B	Ball		6.0~13.8	0.80	3,300	28.5	26.8	55	•	•	•	•	
RBM9733B			6.0~13.8	0.50	2,800	24.0	17.8	51	•	•	•	•	
RBL9733B			6.0~13.8	0.30	2,200	18.8	9.4	45	•	•	•	•	
RBH9733S2	Sleeve	24	12.0~27.6	0.55	3,300	28.5	26.8	55	•	•			
RBM9733S2			12.0~27.6	0.35	2,800	24.0	17.8	51	•	•			
RBL9733S2			12.0~27.6	0.20	2,200	18.8	9.4	45	•	•			
RBH9733B2	Ball		12.0~27.6	0.55	3,300	28.5	26.8	55	•	•			
RBM9733B2			12.0~27.6	0.35	2,800	24.0	17.8	51	•	•			
RBL9733B2			12.0~27.6	0.20	2,200	18.8	9.4	45	•	•			
RBH9733S4	Sleeve	48	24.0~55.2	0.30	3,300	28.5	26.8	55	•	•			
RBM9733S4			24.0~55.2	0.20	2,800	24.0	17.8	51	•	•			
RBL9733S4			24.0~55.2	0.15	2,200	18.8	9.4	45	•	•			
RBH9733B4	Ball		24.0~55.2	0.30	3,300	28.5	26.8	55	•	•			
RBM9733B4			24.0~55.2	0.20	2,800	24.0	17.8	51	•	•			
RBL9733B4			24.0~55.2	0.15	2,200	18.8	9.4	45	•	•			

Notes: ©All readings are typical values at rated voltage.  
©Specifications subjected to change without prior notice.