

93x93x30mm

■ Dimensions Drawing

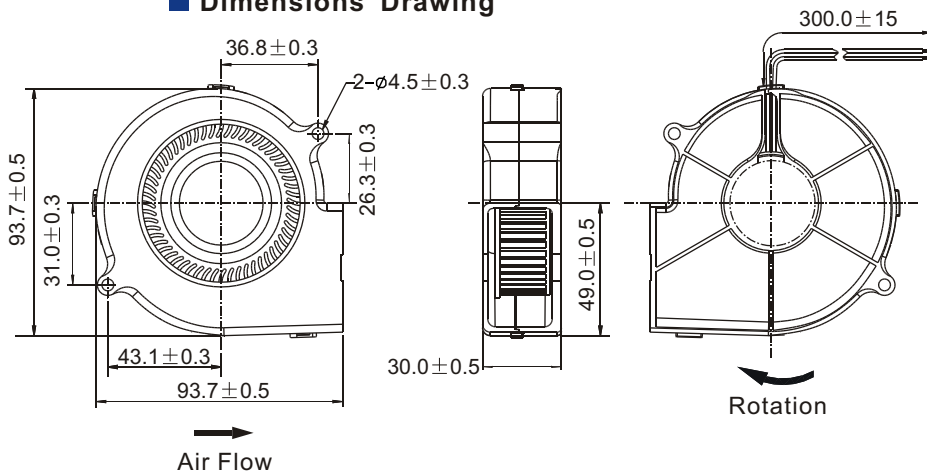
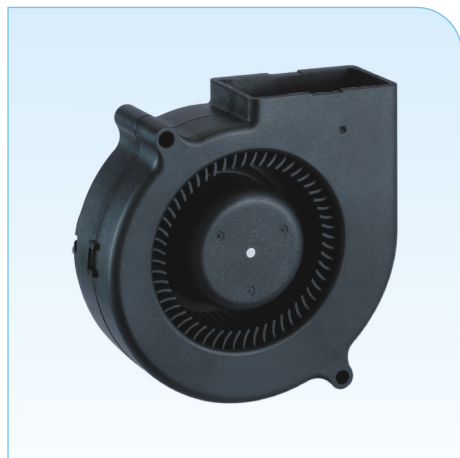

Unit: mm

General Specification:

- Frame and Impeller : Thermal Plastic , UL 94V-0
- Lead Wires : UL Type
(+) : Red (-) : Black
- Operation Temperature : -10°C~70°C、
35%~85%RH
- Storage Temperature : -40°C~80°C、
35%~85%RH



■ Performance Curves

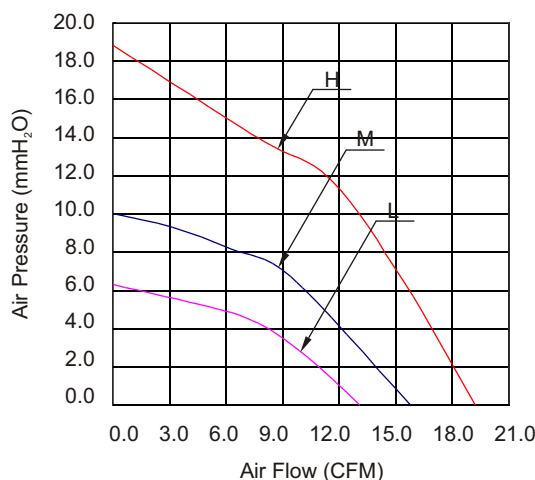

Listed Model	Bearing System	Rated Voltage	Operation Voltage	Rated Current	Rated Speed	Air Flow	Air Pressure	Noise Level	Available Features (Optional)				Weight g
		VDC	VDC	A	RPM	CFM	mmH ₂ O	dBA	Tachometer Output	Rotation Detector	Thermal Control	Pulse Width Modulation	
RBH9330S1	Sleeve	12	6.0~13.8	0.45	3,000	19.2	18.8	45	•	•		•	155
RBM9330S1			6.0~13.8	0.30	2,500	15.8	10.0	42	•	•		•	
RBL9330S1			6.0~13.8	0.20	2,100	13.0	6.3	38	•	•		•	
RBH9330B1	Ball		6.0~13.8	0.45	3,000	19.2	18.8	45	•	•		•	
RBM9330B1			6.0~13.8	0.30	2,500	15.8	10.0	42	•	•		•	
RBL9330B1			6.0~13.8	0.20	2,100	13.0	6.3	38	•	•		•	
RBH9330S2	Sleeve	24	12.0~27.6	0.35	3,000	19.2	18.8	45	•	•			155
RBM9330S2			12.0~27.6	0.15	2,500	15.8	10.0	42	•	•			
RBL9330S2			12.0~27.6	0.10	2,100	13.0	6.3	38	•	•			
RBH9330B2	Ball		12.0~27.6	0.35	3,000	19.2	18.8	45	•	•			
RBM9330B2			12.0~27.6	0.15	2,500	15.8	10.0	42	•	•			
RBL9330B2			12.0~27.6	0.10	2,100	13.0	6.3	38	•	•			