

80x80x25mm

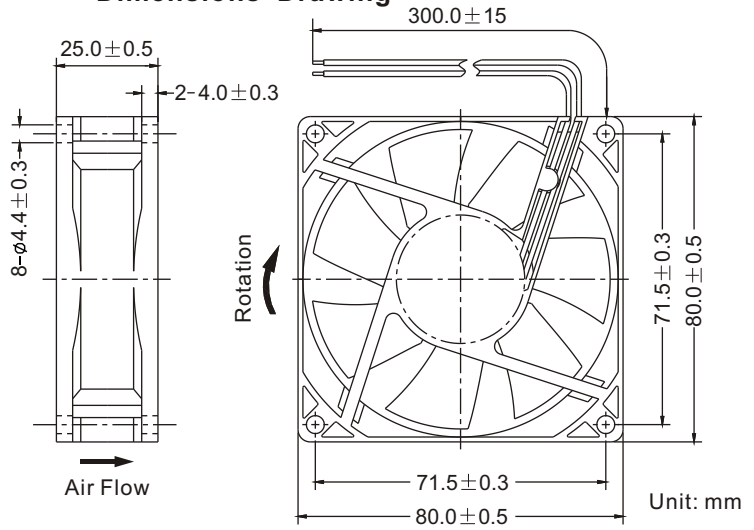

■ Dimensions Drawing



General Specification:

- Frame and Impeller : Thermal Plastic , UL 94V-0
- Lead Wires : UL Type
(+) : Red (-) : Black
- Operation Temperature : -10°C~70°C、
35%~85%RH
- Storage Temperature : -40°C~80°C、
35%~85%RH



■ Performance Curves

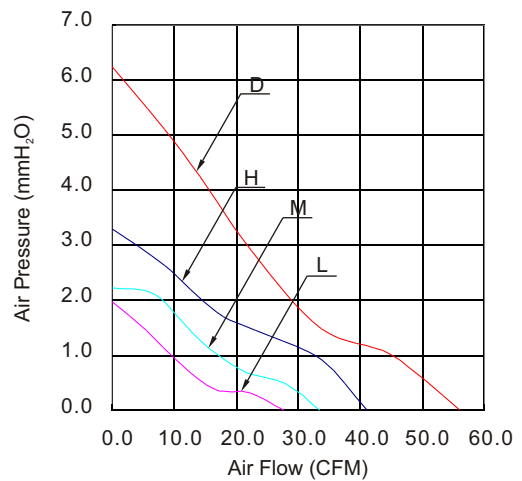

Listed Model	Bearing System	Rated Voltage	Operation Voltage	Rated Current	Rated Speed	Air Flow	Air Pressure	Noise Level	Available Features (Optional)				Weight g
		VDC	VDC	A	RPM	CFM	mmH ₂ O	dBA	Tachometer Output	Rotation Detector	Thermal Control	Pulse Width Modulation	
RDD8025S1	Sleeve	12	6.0~13.8	0.40	4,000	56.0	6.2	43	•	•		•	76
RDH8025S1			6.0~13.8	0.23	3,000	41.0	3.3	33	•	•		•	
RDM8025S1			6.0~13.8	0.16	2,500	33.4	2.2	28	•	•		•	
RDL8025S1			6.0~13.8	0.13	2,000	27.7	1.9	23	•	•		•	
RDD8025B1	Ball		6.0~13.8	0.40	4,000	56.0	6.2	43	•	•		•	
RDH8025B1			6.0~13.8	0.23	3,000	41.0	3.3	33	•	•		•	
RDM8025B1			6.0~13.8	0.16	2,500	33.4	2.2	28	•	•		•	
RDL8025B1			6.0~13.8	0.13	2,000	27.7	1.9	23	•	•		•	
RDH8025S2	Sleeve	24	12.0~27.6	0.15	3,000	41.0	3.3	33	•	•			76
RDM8025S2			12.0~27.6	0.12	2,500	33.4	2.2	28	•	•			
RDL8025S2			12.0~27.6	0.09	2,000	27.7	1.9	23	•	•			
RDH8025B2	Ball		12.0~27.6	0.15	3,000	41.0	3.3	33	•	•			
RDM8025B2			12.0~27.6	0.12	2,500	33.4	2.2	28	•	•			
RDL8025B2			12.0~27.6	0.09	2,000	27.7	1.9	23	•	•			

Notes: ©All readings are typical values at rated voltage.
©Specifications are subjected to change without prior notice.