

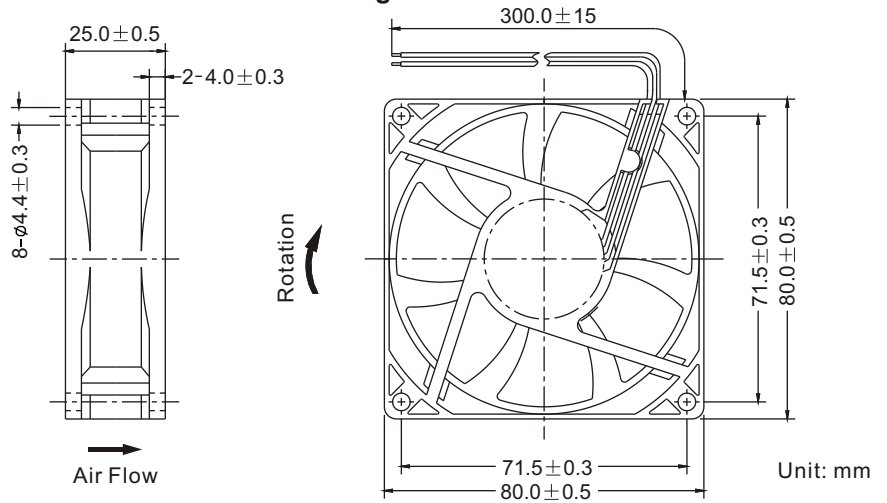

■ Dimensions Drawing



General Specification:

- Frame and Impeller : Thermal Plastic , UL 94V-0
- Lead Wires : UL Type
(+) : Red (-) : Black
- Operation Temperature : -10°C~70°C、
35%~85%RH
- Storage Temperature : -40°C~80°C、
35%~85%RH



■ Performance Curves

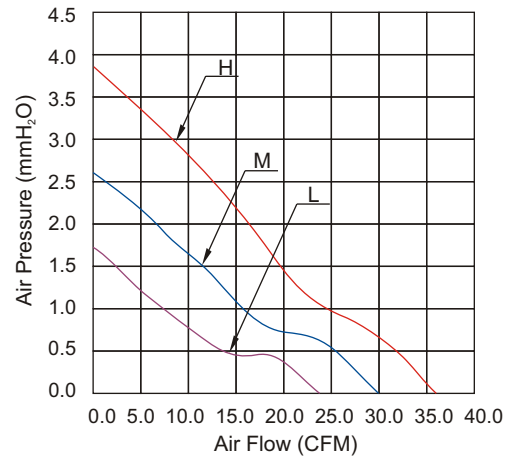

Listed Model	Bearing System	Rated Voltage	Operation Voltage	Rated Current	Rated Speed	Air Flow	Air Pressure	Noise Level	Available Features (Optional)				Weight
		VDC	VDC	A	RPM	CFM	mmH ₂ O	dBA	Tachometer Output	Rotation Detector	Thermal Control	Pulse Width Modulation	g
RDH8025S5	Sleeve	5	3.5~5.75	0.40	3,000	35.7	3.8	33	•	•			76
RDM8025S5			3.5~5.75	0.28	2,500	29.5	2.6	29	•	•			
RDL8025S5			3.5~5.75	0.22	2,000	23.5	1.7	24	•	•			
RDH8025B5	Ball		3.5~5.75	0.40	3,000	35.7	3.8	33	•	•			
RDM8025B5			3.5~5.75	0.28	2,500	29.5	2.6	29	•	•			
RDL8025B5			3.5~5.75	0.22	2,000	23.5	1.7	24	•	•			
RDH8025S	Sleeve	12	6.0~13.8	0.17	3,000	35.7	3.8	33	•	•	•	•	
RDM8025S			6.0~13.8	0.11	2,500	29.5	2.6	29	•	•	•	•	
RDL8025S			6.0~13.8	0.08	2,000	23.5	1.7	24	•	•	•	•	
RDH8025B	Ball		6.0~13.8	0.17	3,000	35.7	3.8	33	•	•	•	•	
RDM8025B			6.0~13.8	0.11	2,500	29.5	2.6	29	•	•	•	•	
RDL8025B			6.0~13.8	0.08	2,000	23.5	1.7	24	•	•	•	•	
RDH8025S2	Sleeve	24	12.0~27.6	0.15	3,000	35.7	3.8	33	•	•			
RDM8025S2			12.0~27.6	0.12	2,500	29.5	2.6	29	•	•			
RDL8025S2			12.0~27.6	0.09	2,000	23.5	1.7	24	•	•			
RDH8025B2	Ball		12.0~27.6	0.15	3,000	35.7	3.8	33	•	•			
RDM8025B2			12.0~27.6	0.12	2,500	29.5	2.6	29	•	•			
RDL8025B2			12.0~27.6	0.09	2,000	23.5	1.7	24	•	•			

Notes: ©All readings are typical values at rated voltage.
©Specifications are subjected to change without prior notice.