

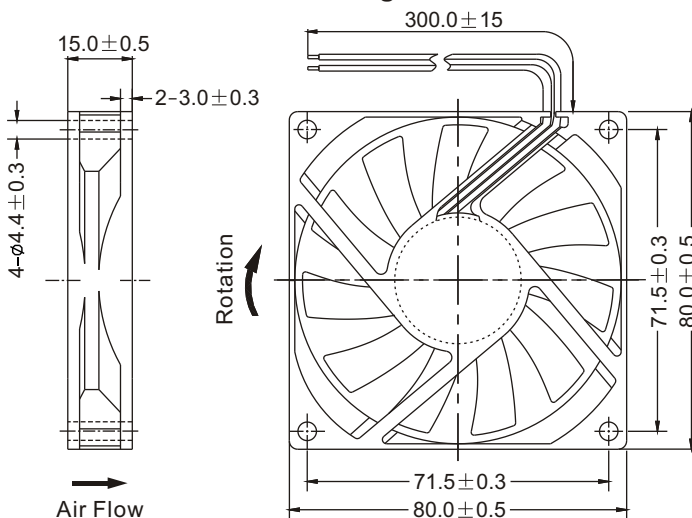

■ Dimensions Drawing



Unit: mm

General Specification:

- Frame and Impeller : Thermal Plastic , UL 94V-0
- Lead Wires : UL Type
(+) : Red (-) : Black
- Operation Temperature : -10°C~70°C、
35%~85%RH
- Storage Temperature : -40°C~80°C、
35%~85%RH



(12V)



(24V)

■ Performance Curves

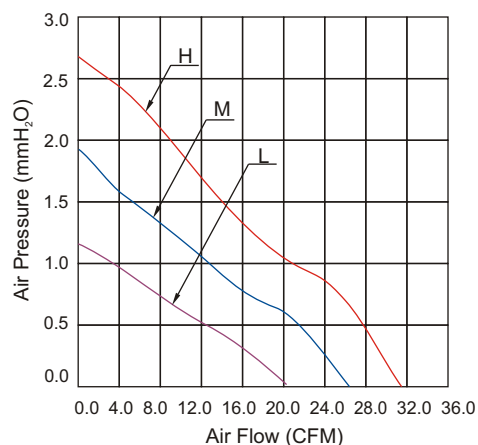

Listed Model	Bearing System	Rated Voltage	Operation Voltage	Rated Current	Rated Speed	Air Flow	Air Pressure	Noise Level	Available Features (Optional)				Weight
		VDC	VDC	A	RPM	CFM	mmH ₂ O	dBA	Tachometer Output	Rotation Detector	Thermal Control	Pulse Width Modulation	g
RDH8015S1	Sleeve	12	6.0~13.8	0.17	3,000	31.2	2.6	35	•	•		•	54
RDM8015S1			6.0~13.8	0.14	2,500	26.0	1.9	30	•	•		•	
RDL8015S1			6.0~13.8	0.09	2,000	20.8	1.2	25	•	•		•	
RDH8015B1	Ball		6.0~13.8	0.17	3,000	31.2	2.6	35	•	•		•	
RDM8015B1			6.0~13.8	0.14	2,500	26.0	1.9	30	•	•		•	
RDL8015B1			6.0~13.8	0.09	2,000	20.8	1.2	25	•	•		•	
RDH8015S2	Sleeve	24	12.0~27.6	0.15	3,000	31.2	2.6	35	•	•			54
RDM8015S2			12.0~27.6	0.13	2,500	26.0	1.9	30	•	•			
RDL8015S2			12.0~27.6	0.10	2,000	20.8	1.2	25	•	•			
RDH8015B2	Ball		12.0~27.6	0.15	3,000	31.2	2.6	35	•	•			
RDM8015B2			12.0~27.6	0.13	2,500	26.0	1.9	30	•	•			
RDL8015B2			12.0~27.6	0.10	2,000	20.8	1.2	25	•	•			

Notes: ©All readings are typical values at rated voltage.
©Specifications are subjected to change without prior notice.