

120x120x38mm

■ Dimensions Drawing

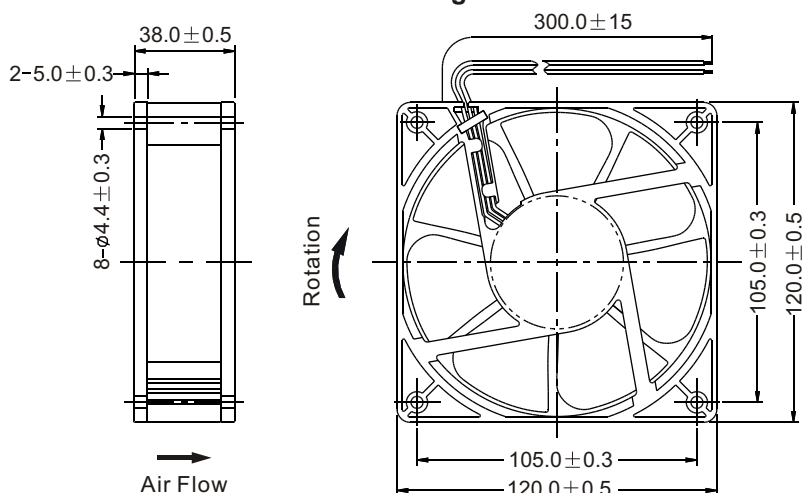

Unit: mm

General Specification:

- Frame and Impeller : Thermal Plastic , UL 94V-0
- Lead Wires : UL Type  
(+) : Red (-) : Black
- Operation Temperature : -10°C~70°C、  
35%~85%RH
- Storage Temperature : -40°C~80°C、  
35%~85%RH



■ Performance Curves

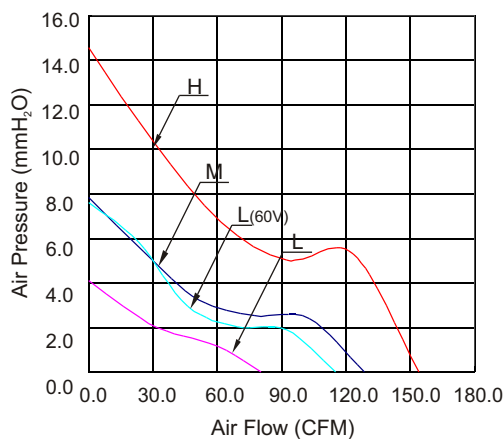

Listed Model	Bearing System	Rated Voltage	Operation Voltage	Rated Current	Rated Speed	Air Flow	Air Pressure	Noise Level	Available Features (Optional)				Weight
		VDC	VDC	A	RPM	CFM	mmH <sub>2</sub> O	dBA	Tachometer Output	Rotation Detector	Thermal Control	Pulse Width Modulation	g
RDH1238S1	Sleeve	12	6.0~13.8	1.30	3,800	154.0	14.6	52	•	•	•	•	290
RDM1238S1			6.0~13.8	0.58	2,900	128.7	7.8	44	•	•	•	•	
RDL1238S1			6.0~13.8	0.28	2,000	80.4	4.1	35	•	•	•	•	
RDH1238B1	Ball		6.0~13.8	1.30	3,800	154.0	14.6	52	•	•	•	•	
RDM1238B1			6.0~13.8	0.58	2,900	128.7	7.8	44	•	•	•	•	
RDL1238B1			6.0~13.8	0.28	2,000	80.4	4.1	35	•	•	•	•	
RDH1238S2	Sleeve	24	12.0~27.6	0.60	3,800	154.0	14.6	52	•	•	•	•	290
RDM1238S2			12.0~27.6	0.40	2,900	128.7	7.8	44	•	•	•	•	
RDL1238S2			12.0~27.6	0.30	2,000	80.4	4.1	35	•	•	•	•	
RDH1238B2	Ball		12.0~27.6	0.60	3,800	154.0	14.6	52	•	•	•	•	
RDM1238B2			12.0~27.6	0.40	2,900	128.7	7.8	44	•	•	•	•	
RDL1238B2			12.0~27.6	0.30	2,000	80.4	4.1	35	•	•	•	•	
RDH1238S4	Sleeve	48	24.0~55.2	0.35	3,800	154.0	14.6	52	•	•	•	•	290
RDM1238S4			24.0~55.2	0.30	2,900	128.7	7.8	44	•	•	•	•	
RDL1238S4			24.0~55.2	0.20	2,000	80.4	4.1	35	•	•	•	•	
RDH1238B4	Ball		24.0~55.2	0.35	3,800	154.0	14.6	52	•	•	•	•	
RDM1238B4			24.0~55.2	0.30	2,900	128.7	7.8	44	•	•	•	•	
RDL1238B4			24.0~55.2	0.20	2,000	80.4	4.1	35	•	•	•	•	
RDL1238B6	Ball	60	36.0~72.0	0.30	2,600	115.0	7.6	41	•	•	•	•	290

Notes: ©All readings are typical values at rated voltage.  
©Specifications are subjected to change without prior notice.